

# TC.GSX.32.65.4WR.S

## Programmable DC Power Supply with Active PFC



### Features

#### TC.GSX Series (with Active PFC)

TopCon Grid-tie Source technology allows for high efficient full source mode operation in compact design.

Constant voltage (0...100%), constant current (0...100%) and constant power operation (5...100%) with automatic controller crossover and mode indication. Internal resistance simulation.

Graduated product line: 65 V<sub>DC</sub>, 130 V<sub>DC</sub>, 400 V<sub>DC</sub>, 500 V<sub>DC</sub>, 600 V<sub>DC</sub>, higher voltages with series connection up to 2000 V<sub>DC</sub>. Power categories of 20 kW and 32 kW are available for each nominal output voltage.

Optional extras and accessories available.

Modular concept for easy power increase: Parallel, series, matrix or multiload master-slave-operation.

High efficiency by innovative switching and transformer technology galvanic isolation. Full digital control and regulation.

The user-friendly operating and service software TopControl is included in the scope of delivery.

LabVIEW® and C/C++ C#/ .NET API (DLL file) are included in the scope of delivery.

### Technical Data

#### Key Values

Power range	0 kW...32 kW <sup>3)</sup>
Voltage range	0 V <sub>DC</sub> ...65 V <sub>DC</sub>
Current range	0 A...600 A <sup>3) 10)</sup>
Master-Slave / multi-device configuration	series, parallel, mixed
Max. number of devices in system	16 <sup>12)</sup>
Max. number in parallel	16
Max. number in series	10 <sup>13)</sup>
Case	19" / 9 U

#### AC Lineside Ratings

Line voltage / Line current	3 x 380 V <sub>AC</sub> ±10% / 54 A <sub>rms</sub> <sup>1) 10)</sup>
	3 x 400 V <sub>AC</sub> ±10% / 51 A <sub>rms</sub> <sup>1)</sup>
	3 x 415 V <sub>AC</sub> ±10% / 49 A <sub>rms</sub> <sup>1)</sup>
	3 x 440 V <sub>AC</sub> ±10% / 47 A <sub>rms</sub> <sup>1)</sup>
	3 x 460 V <sub>AC</sub> ±10% / 45 A <sub>rms</sub> <sup>1)</sup>
	3 x 480 V <sub>AC</sub> ±10% / 43 A <sub>rms</sub> <sup>1)</sup>
Rated frequency	50/60 Hz
Mains connection type	3L + PE (no neutral)
Protective conductor current @50 Hz	<20 mA <sup>2)</sup>
Touch current unweighted	<20 mA <sup>2)</sup>
Touch current weighted	<2 mA <sup>2)</sup>
Powerfactor @P <sub>nom</sub>	≥0.99
Efficiency at nominal power	90% <sup>9)</sup>
Input filter discharge to <60 V:	< 20 s
with option XCD	< 1 s

#### DC Operation

Operation mode	source mode
Voltage regulation (CV)	0%...100% U <sub>nom</sub>
Current regulation (CC)	0%...100% I <sub>nom</sub>
Power regulation (CP)	5%...100% P <sub>nom</sub>
Internal resistance range	0 mΩ...110 mΩ <sup>4)</sup>
Switchable output capacitance	6 mF / 17.2 mF
Ballast resistor	100 Ω
Output discharge time to <60V	<0.5 s

#### Static accuracy

Line and Load regulation CV	<±0.1% FS <sup>5) 6)</sup>
Line and Load regulation CC	<±0.05% FS <sup>5) 6)</sup>

#### Transient response time

Load regulation CV	<1.5 ms <sup>7)</sup>
Set value tracking CV	<1.5 ms <sup>8) 11)</sup>
Set value tracking CC:	
With quadrant change	<2 ms <sup>8)</sup>
Without quadrant change	<2 ms <sup>8)</sup>

- 1) At nominal output power and nominal line voltage. Soft-start to limit turn-on surge currents.
- 2) According to IEC60990: Protective conductor current: 50 Hz component @ 400 V<sub>AC</sub>/50 Hz/P<sub>nom</sub>. For weighted touch current: Measured for perception/reaction. Protection with earth leakage circuit breaker possible. An additional PE connection is necessary.
- 3) Current according to the given power limit of the corresponding units. (P = U<sub>Load</sub> \* I<sub>Load</sub> ≤ 32 kW; for I<sub>Load</sub> > 492 A → U<sub>Load</sub> < 65 V).
- 4) The maximum value of the internal resistance is automatically calculated via the DC nominal values (Ri [mΩ] = U<sub>Load</sub> / I<sub>Load</sub> = 65 V<sub>DC</sub> / 600 A) or limited by the maximum Ri-value: 32000 [mΩ].
- 5) Typical value for 0...100% load variation, at constant line input and temperature conditions.
- 6) Typical value for input voltage variation within 380 V<sub>AC</sub> ±10%...480 V<sub>AC</sub> ±10%, at constant load and temperature conditions.
- 7) Typical recovery time to within ±5% band of set value for a load step 10...90%, ohmic load, at constant line input and temperature conditions. Transient response time can be slightly affected by multi-device operation.
- 8) Rise/ fall time for 10%...90% of a set step.
- 9) At 15 kHz switching frequency line side inverter.
- 10) Information about derating see section deratings.
- 11) Typical value at nominal ohmic load, line asymmetry <1 V<sub>rms</sub>.
- 12) More with TC.MAC
- 13) With midpoint earthing, limited by output isolation to PE

**DC Operation (continued)**

**Stability**

Voltage regulation (CV)	<±0.05% FS <sup>1)</sup>
Current regulation (CC)	<±0.05% FS <sup>1)</sup>

**Ripple**

≤300 Hz V <sub>pp</sub>	<0.2% FS <sup>2)</sup>
≤300 Hz V <sub>rms</sub>	<0.05% FS <sup>2)</sup>

**Noise**

40 kHz...1 MHz V <sub>pp</sub>	<0.2 V <sup>2)</sup>
40 kHz...1 MHz V <sub>rms</sub>	<0.05 V <sup>2)</sup>

**Temperature coefficient**

Voltage regulation (CV)	<0.02% FS / K <sup>3)</sup>
Current regulation (CC)	<0.03% FS / K <sup>3)</sup>

**Isolation**

Line to case / logic	1670 V <sub>DC</sub> (1 s)
Output to case / logic	2060 V <sub>DC</sub> (1 s)
Output to case	10.8 MΩ / high impedance (X109 open)
- bar to case <sup>4)</sup>	+680 V <sub>DC</sub> / -680 V <sub>DC</sub>
+ bar to case <sup>4)</sup>	+680 V <sub>DC</sub> / -680 V <sub>DC</sub>
Capacitance to case per DC bar	35 nF

**Protection**

**Built-in protection**

Overtemperature	
Overvoltage (programmable)	0%...110% U <sub>nom</sub>
Overcurrent (programmable)	0%...110% I <sub>nom</sub>
Overpower (programmable)	0%...110% P <sub>nom</sub>
Response time	50 μs...1600 ms
Max. reactive load voltage	≤110% U <sub>nom</sub>
Short circuit protection	Cont. short circuit allowed
Islanding, grid off, requirements for the connection of micro-generators in public grid according VDE 0126/EN 50438.	

**Type of protection (according EN 60529)**

Basic construction	IP 20 (current bars on rear side excluded)
Mounted in cabinet	Up to IP 54

**Sensing**

Sense voltage compensation	Programmable
U <sub>out</sub> + U <sub>drop</sub> limited by U <sub>out max</sub>	

**I/O Interface**

**I/O Interface X105 (analog / digital)**

25 pin D-sub connector, female	on rear panel
Isolation to electronics and earth	125 V <sub>rms</sub>

**Control port input functions:**

Output voltage off / on	0 / 24 V <sub>DC</sub>
2 digital application inputs	0 / 24 V <sub>DC</sub> <sup>5)</sup>
Interlock circuit	0 / 24 V <sub>DC</sub>
Voltage setting 0%...100%	0 V...10 V
Current setting 0%...100%	0 V... 10 V
Power setting 0%...100%	+10 V...0 V <sup>6)</sup>
Int. resistance setting 0%...100%	0 V...10 V
Input impedance analog inputs	20 kΩ

**Control port output functions:**

Unit ready / error	Relay contact
Output voltage on	Relay contact
Warnings	Relay contact
Actual voltage readback 0%...100%	0 V...10 V
Actual current readback 0%...100%	0 V...10 V
Sampling rate	10 kHz

**Resolution (programming and readback):**

U, I, P, Ri	0.2% FS
-------------	---------

**Delay time (programming and readback):**

Analog in to DC output	175 μs typ. <sup>7)</sup>
DC output to analog out	200 μs typ. <sup>7)</sup>

**Communication Interfaces**

**RS232**

9 pin D-sub connector, female	on front panel
Isolation to electronics and earth	125 V <sub>rms</sub>
Baud rate	38400 baud

**Resolution (programming and readback):**

U, I	0.025% FS
P, Ri	0.1% FS

**Deratings**

**Power derating**

Linear power derating < 360 VAC in source mode operation to 30.2 kW @ 340 VAC.

**Current derating**

Source mode:  
Max. permanent output source current  
@ 53 VDC / < 35 °C: 600 ADC  
@ 53 VDC / < 40 °C: 540 ADC  
Higher current, if CDF < 100%

1) Maximum drift over 8 hours after 30 minutes warm-up time, at constant line input, load and temperature conditions.  
2) Typical value at nominal ohmic load, line asymmetry <1 V<sub>rms</sub>.  
3) Typical change of output values versus ambient temperature, at constant line input and load conditions.  
4) Maximum working voltage including DC output voltage.  
5) Customer-specific programmable  
6) For the source mode only power settings +10 V...0 V possible.  
7) Delay time can be slightly affected by multi-device operation.

## User Software

### Application Software TopControl

The user-friendly operating and service software TopControl is included in the scope of delivery.

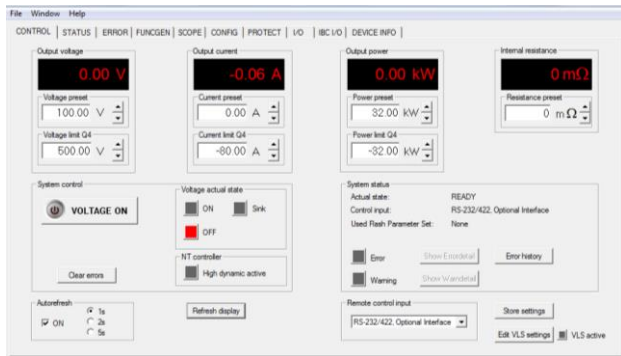

Remote connection via PC interfaces: E.g. RS232 and further interface options.

System operation (parallel or series mode)

TopControl is the user interface software and environment for the additional software option like TFEAAP (FUNGGEN) or CANmp.

## General Data

### Weight & Dimension

Weight	97 kg
Width front panel	483 mm / 19"
Width housing	444 mm / 17 1/2"
Height front panel	400 mm / 9 U / 15 3/4"
Depth with output terminals	635 mm / 25"
Depth housing	594 mm / 23 3/8"

### Terminals

AC lineside terminals	4 x 25 mm <sup>2</sup>
DC loadside terminals	40 mm, 1 hole 9 mm Ø in each bar nickel-plated copper bars

### Ambient

Operating temperature	5...40 °C
Storage temperature (with coolant)	-18...70 °C
Relative air humidity (non-condensing)	0...95%
Installation altitude	0...2000 m above sea level <sup>1)</sup>
Installation	in protected 19" switch cabinet IEC 60721-3-3 indoor, air-conditioned
Vibration	IEC 60068-2-6 Test Fc
Operating orientation	upside
Storage, transport orientation	upside

### Cooling

Internal liquid to air heat-exchange system using temperature-controlled fans.

Coolant	Antifrogen® N Clariant
---------	------------------------

### Standards

Protection class	I
Overvoltage category	III
Degree of pollution	2
Area of application	industrial

### Approval CE

Low Voltage Directive 2014/35/EU	EN 62477-1:2012 + A11 :2014 + A1 :2017 + A12 :2021
----------------------------------	--

EMC Directive 2014/30/EU	
EMC immunity (industrial)	EN 61000-6-2:2005
EMC emission (industrial)	EN 61000-6-4:2007 + A1:2011
RoHS Directive 2011/65/EU	EN IEC 63000:2018

### Approval UKCA

Electrical Equipment (Safety) Regulations 2016	BS EN 62477-1:2012 + A11 :2014 + A1 :2017 + A12 :2021
--	---

Electromagnetic Compatibility Regulations 2016	
EMC immunity (industrial)	BS EN 61000-6-2:2005
EMC emission (industrial)	BS EN 61000-6-4:2007 + A1:2011

The Restriction of the Use of Certain Hazardous Substances in Electrical and Electronic Equipment Regulations 2012	BS EN IEC 63000:2018
--	----------------------

### Scope of delivery

Operating manual	English or German
RS232 cable	1.8 m
Dummy plugs	X101 and X105

### Software

TopControl	on memory stick
API (DLL files)	LabVIEW® and C /C++ / C# / .NET API

1) above 1000 m, slight temperature derating possible

## Options

### Safety

ISR <sup>1)</sup>	2 channel Integrated Safety Relay
RPP.G <sup>1)</sup>	Reverse Polarity Protection
PAC.G.DC	Protection against accidental contact
PAC.G.AC	Protection against accidental contact
SELV <sup>1)</sup>	(Safety Extra Low Voltage)
Requires option ISR	

### Software

TFEAPControl	TopCon Function Generating Engine Time-based and parametric programming PV curves or user defined curves (csv files)
SASControl	SAS application program including TFEAAP
BatControl	Battery testing program
BatSim	Battery simulation program

### Communication Interfaces

USB <sup>1) 2)</sup>	
ETHERNET <sup>1) 2)</sup>	
LXI <sup>1) 2)</sup>	
IEEE 488.2 / GPIB / SCPI <sup>1) 2)</sup>	cannot be combined with CANOPEN nor with USB
CANmp <sup>1)</sup>	Fast multi-protocol CAN
CANOPEN <sup>1) 2)</sup>	
RS232REAR <sup>1)</sup>	
RS422 <sup>1) 2)</sup>	

### Displays

#### Human machine interface unit (HMI)

Integrated control, programming and display unit with graphic LC-Display, select wheel, push buttons and interactive text menus

Languages (switchable)	English, German
Display resolution:	
U	4 digits
I	3 digits
P	Kilowatt + 1 decimal digit
Ri	1 mΩ

#### Remote control unit (RCU)

Specifications same as HMI, available in 2 versions:

Desktop W x H x D	356 x 101 x 290 mm 14" x 4" x 11 3/8"
19" Rack-Mount W x H x D	483 x 89 (2 U) x 70 mm 19" x 3 1/2" x 2 3/4"

### AIRFILTER

Front panel airfilter 9 U

#### Derating

When using the Air Filter, a possible derating will start at a lower temperature (approx. 3 °C less).

### LC (Liquid Cooling) <sup>1)</sup>

Integrated liquid cooling system of the power stage with completely integrated liquid to liquid heat-exchange system.

#### Specifications

Material <sup>3)</sup>	Stainless steel
Inlet/outlet on rear side size	G 1/2"
Liquid temperature (noncondensing)	15...35 °C
Flow	≥3 l/min
Recommended flow	4...6 l/min
Pressure max.	4 bar
Pressure drop	50 mbar @3 l/min
Pressure drop @quick connect non-drip	240 mbar @4.5 l/min

#### Miscellaneous

NSOV	Non-Standard output voltage (if possible)
NSOC	Non-Standard output current (if possible)
NSOP	Non-Standard output power (if possible)

#### Environment

SAV	Ruggedized against shock and vibration
ENV	Protection against environmental influence

For more details see separate datasheet.

#### System operation

#### CANCABLE

Connecting cable for multi-device Systems or RCU	
Cable length	2, 5, 10, max. 40 m

#### TC.MAC (Master Array Controller)

Required for multi-device Systems with more than 16 power supplies. Controls several subsystems of up to 16 power supplies to reach MW range.

MACInterface	Interface for using TC.MAC
MACCABLE	to connect Subsystem to TC.MAC
Cable length	2, 5, 10, max. 40 m

## Order code

TC.GSX.32.65.4WR.S (.LC / .HMI)

1. Retrofitting on request  
 2. This option and RS232: time-shared mode required, if use together.  
 3. Ni brazed, ready to use with deionized water.

## Further Description Details

### Operating area

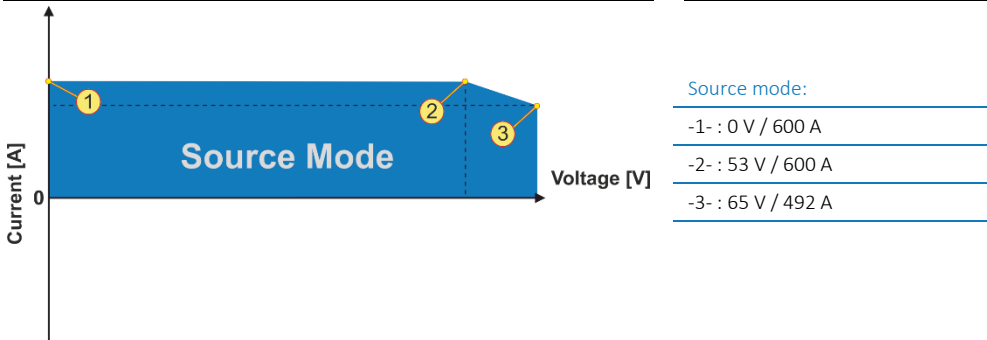

Figure 1: TC.GSX.32.65.4WR.S, voltage/current operating area

### Dimensions

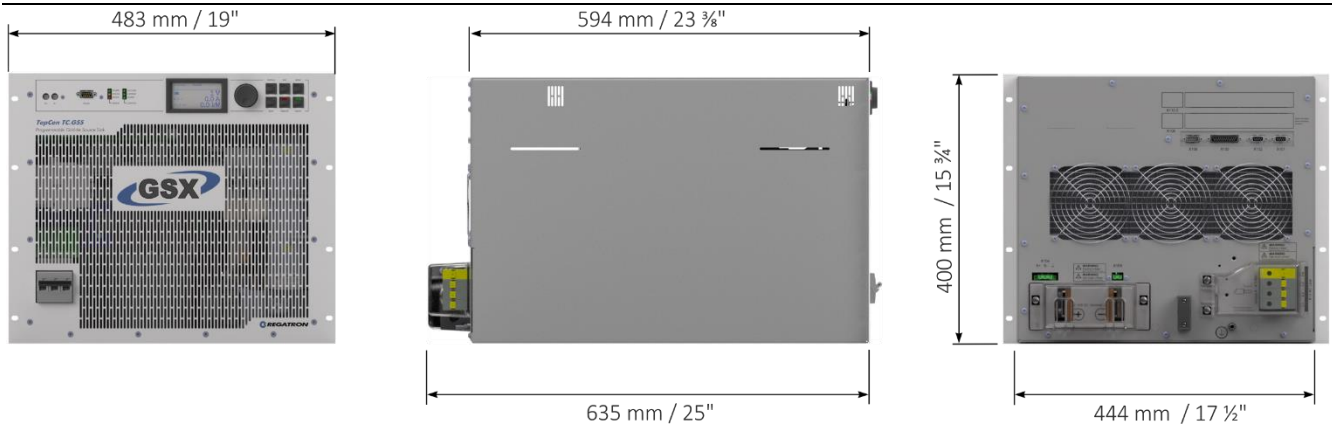

Figure 2: Front, right hand side and rear view. 19-inch module with 9 units in height.

This product is developed, produced and tested according to ISO 9001 by REGATRON.

For detailed technical information, contact your local sales partner or REGATRON.

Regatron AG Feldmuehlestrasse 50 9400 Rorschach SWITZERLAND sales@regatron.com www.regatron.com	Regatron Inc. 100 Overlook Center, 2 <sup>nd</sup> Floor Princeton, NJ 08540 USA inquiries@us.regatron.com www.us.regatron.com
--	---

All product specifications and information contained herein are subject to change without notice.

Filename: DS\_TC.GSX.32.65.4WR.S\_EN\_230301

Class: Public