



PM50-series 32 to 50 W 1&2 outputs

INPUT / OUTPUT

- Wide input voltage ranges
- Input ranges from 10 to 270 Vd.c.
- Single outputs from 12 to 132 Vd.c.
- Two isolated outputs 12-16, 18 or 60 Vd.c.
- Reverse input voltage protection

OPERATION

- Operating temperature range -25 to +55 °C (-40 °C on request)
- Fully encapsulated, meets IP20 as standard.
- Convection cooled

SINGLE OUTPUTS

OUTPUT			INPUT				Connection
Voltage	Current	Power	10 - 30 V	20 - 60 V	50 - 150 V	90 - 270 V	
12 V	2.67 A	32 W	PM50A15-15				Parallel
12 V	3.34 A	40 W		PM50B15-15	PM50C15-15	PM50D15-15	Parallel
15 V	2.67 A	40 W	PM50A15-15				Parallel
15 V	3.34 A	50 W		PM50B15-15	PM50C15-15	PM50D15-15	Parallel
18 V	2.60 A	47 W	PM50A18-18				Parallel
18 V	3.20 A	57 W		PM50B18-18			Parallel
18 V	2.78 A	50 W			PM50C18-18		Parallel
24 V	1.34 A	32 W	PM50A15-15				Series
24 V	1.67 A	40 W		PM50B15-15	PM50C15-15	PM50D15-15	Series
28 V	1.34 A	37 W	PM50A15-15				Series
28 V	1.67 A	47 W		PM50B15-15	PM50C15-15	PM50D15-15	Series
36 V	1.30 A	47 W	PM50A18-18				Series
36 V	1.60 A	57 W		PM50B18-18			Series
36 V	1.39 A	50 W			PM50C18-18		Series
60 V	0.67 A	40 W	PM50A60-60				Parallel
60 V	0.84 A	50 W		PM50B60-60	PM50C60-60	PM50D60-60	Parallel
110 V	0.34 A	37 W	PM50A60-60				Series
110 V	0.42 A	46 W		PM50B60-60	PM50C60-60	PM50D60-60	Series

How to read our product code: Example PM50B15-15

PM50 = Family code, B = input voltage code B, 15-15 = Two outputs with nom. voltage 12-16 V

FEATURES

- Wall or DIN-rail mounting
- One unit covers many output voltages
- Output voltage adjustable on frontpanel.

OPTIONAL FEATURES

- Conformally coating; tropical version for environment with high non condensing humidity max 98 % RH.

EMC

- EN IEC 61000-6-3, Emission.
- EN IEC 61000-6-2, Immunity.
- EN IEC 61000-4-4, 4 kV.
- EN IEC 61000-4-5 level 2 & 3.

DUAL OUTPUTS

OUTPUT					INPUT			
Voltage	Current	Voltage	Current	Power	10 - 30 V	20 - 60 V	50 - 150 V	90 - 270 V
12 V	1.34 A	12 V	1.34 A	32 W	PM50A15-15			
12 V	1.67 A	12 V	1.67 A	40 W		PM50B15-15	PM50C15-15	PM50D15-15
15 V	1.34 A	15 V	1.34 A	40 W	PM50A15-15			
15 V	1.67 A	15 V	1.67 A	50 W		PM50B15-15	PM50C15-15	PM50D15-15
18 V	1.30 A	18 V	1.30 A	47 W	PM50A18-18			
18 V	1.60 A	18 V	1.60 A	57 W		PM50B18-18		
18 V	1.39 A	18 V	1.39 A	50 W			PM50C18-18	
60 V	0.34 A	60 V	0.34 A	40 W	PM50A60-60			
60 V	0.42 A	60 V	0.42 A	50 W		PM50B60-60	PM50C60-60	PM50D60-60

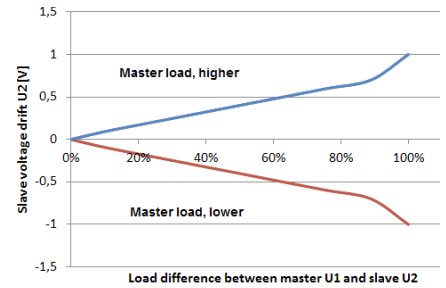

Figure 1. Voltage different between U1 & U2 depending on load difference on PM50*15-15. On PM50*60-60 the voltage different is relatively smaller.

DC INPUTS

NOMINAL INPUTS	INPUT RANGE	CODE
12, 24 Vd.c.	10 - 30 V	A
24, 28, 36, 48 Vd.c.	20 - 60 V	B
72, 96, 110, 127 Vd.c.	50 - 150 V	C
110, 127, 220, 250 Vd.c.	90 - 270V	D

Input voltages meeting train standard EN 50155/IEC 60571, can be made on demand

GENERAL DATA / INPUT DATA

LABEL	VALUE
Design topology	Flyback
Switching frequency	typ. 45 kHz
Emission / Immunity	See page 4
Safety EN IEC 60950	Class I
Max. accepted input ripple ¹ 50-400 Hz	2 % of nominal voltage
Input power at no load	< 5 W
Inrush current limit	No
Reverse input voltage protection	
A, B input code	Parallel diode
C, D input code	Series diode
Dimensions (D x W x H)	157 x 106 x 48 mm
Weight	0.65 kg
Power connector	0,25 - 2,5 mm ²

1. Higher ripple affects the input, contact factory

HOW TO CONNECT THE OUTPUTS

Use the supplied jumpers shown below

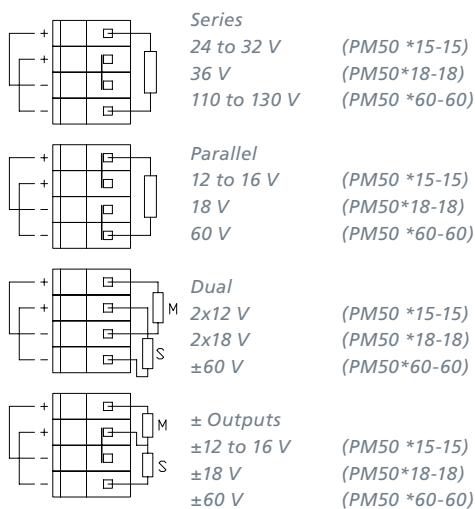

* = Input voltage code. M = Master output U1. S = Slave output U2.

Figure 2. Jumper position on PM50 connector (Series & Parallel)

OUTPUT DATA

LABEL	VALUE
Source regulation	0.2%
Load regulation parallel outputs	0.2%
Load regulation with series connected outputs 10-100% load	1%
Load regulation on U1	0.2%
Load regulation on U2	See figure 1
Transient recovery time for 10 to 90% load step to within 3% of nominal output voltage.	Typ. <3 ms
Output ripple (45 kHz)²	
PM50A15-15, PM50*15-15	Typ. 1 mV _{RMS}
PM50A60-60, PM50*60-60	Typ. 2 mV _{RMS}
Input ripple attenuation to output (50 to 400 Hz)	150:1
Emission / Immunity	See page 4
Temperature coefficient	0.02%/°C
Output adjustment range adjustable with a 15 turn potentiometer	
PM50*15-15	12 - 16 V
PM50*18-18	17 - 20 V
PM50*60-60	54 - 66 V
Current limit, fold-back	See figure 3
Remote sense	No
Soft start	No
Start-up time	1 s
Hold-up time, contact factory	2 - 25 ms
Efficiency ³	78 - 85 %
Operating temperature range at 100% load ⁴	-25 to +55 °C
Storage temperature range	-40 to +85 °C

- The output ripple might increase to 0.5% RMS of Vout, when EN IEC 61000-4-3, 10 V/m test is applied.
- Lowest efficiency measured within the whole input voltage range at 100% load.
- 40 °C on request.

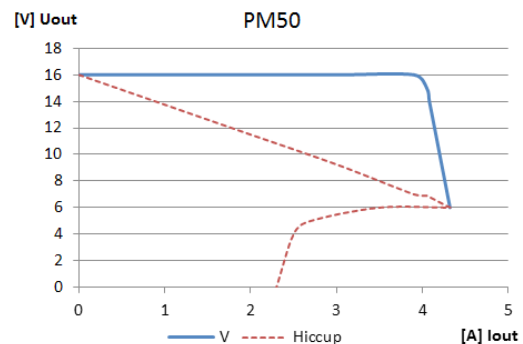

Figure 3. Current limit characteristic for PM50*15-15 with outputs connected in parallel.

MECHANICAL DRAWING

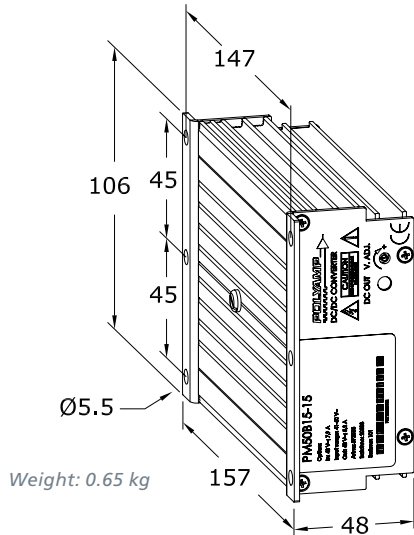
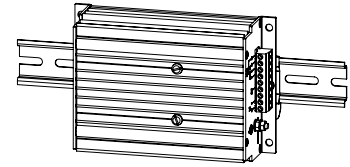
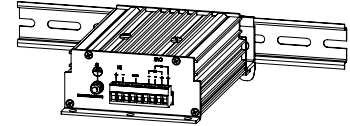

Figure 4. Dimensions



PM50/80 Wall or DIN-rail mounted (standard)



PM50/80 DIN-rail mounted L60-1 (option)

OUTPUT VOLTAGE/POWER CHARACTERISTICS

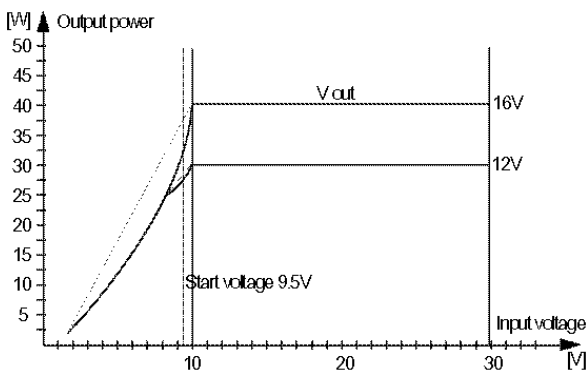

Figure 5. Output power PM50A15-15

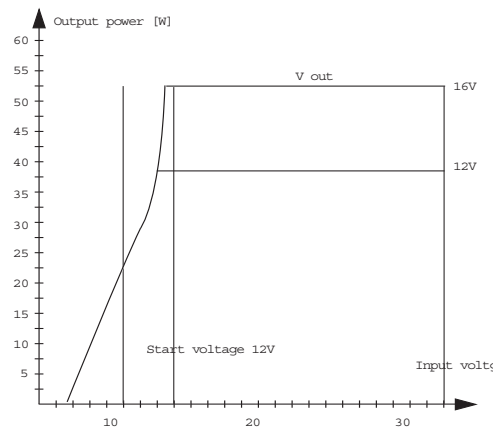

Figure 6. Output power PM50B15-15

The PM50 series have no low input voltage lock-out, which stops the converter. The output power is instead automatically derated, see figures 5 to 8. Example: PM50A15-15, figure 6, has start voltage at 9.5 V and can supply 15 W output power at 6 V input.

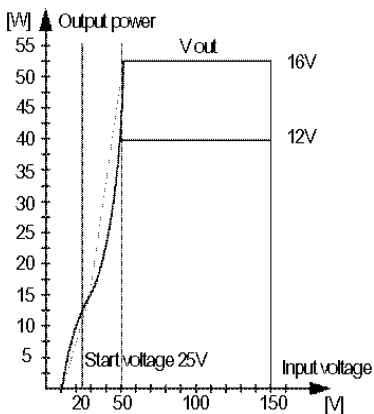

Figure 7. Output power PM50C15-15

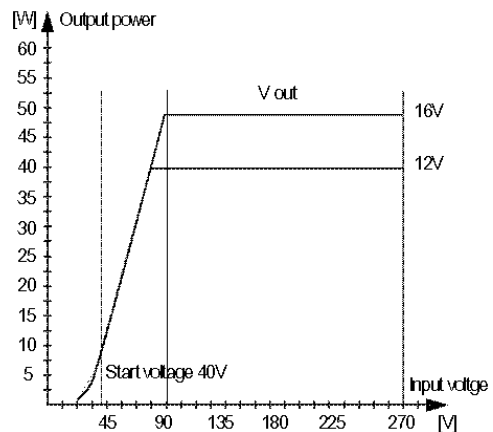

Figure 8. Output power PM50D15-15

CE MARK

PM50 meets the requirements defined by CE mark as apparatus.

PM50 meets requirements of EMC directive and low voltage directive (LVD) and RoHS II directive.

The PM50 family is in respect to EMC, a stand alone unit that can also be installed in any other environment by a professional installer.

Please note that product standards can demand different levels or other basic standard tests. We test according to levels below. For higher levels or other tests, contact factory

SAFETY STANDARD EN/IEC 60950

ISOLATION TESTABLE LEVELS	TEST VOLTAGE
Input / Output: Input code A, B	2 kVd.c.
Input code C, D	2.5 kVa.c. / 4 kVd.c.
Input / Case: Input code A, B	2 kVd.c.
Input code C, D	2.5 kVa.c. / 4 kVd.c.
Output / Case all outputs	1 kVd.c.
Between U1 / U2	500 kVd.c.

EMC

EMC STANDARDS	EMC PERFORMANCE		REMARKS
Emission standards	EN IEC 61000-6-3		Commercial and light-industrial environments
	Input	Output	
EN 55016 CISPR 16 (0.15-30 MHz)	OK	OK	opt.EN 55022 level B
EN 55016 CISPR 16 (30-1000 MHz)	OK		Enclosure test
Immunity standards	EN IEC 61000-6-2		Industrial environments
EN IEC 61000-4-2	8 kV / 15 kV		Contact / air, Enclosure test
EN IEC 61000-4-3	10 V/m AM-Modulated		Output ripple can increase to 0.5% of Vout Enclosure test
EN IEC 61000-4-4	± 4 kV	± 4 kV	
EN IEC 61000-4-5, Input code A, B	± 0.5 kV / ± 1 kV	± 0.5 kV / ± 1 kV	Line-line 2 Ω / Line-case 12 Ω
EN IEC 61000-4-5, Input code C, D	± 1 kV / ± 2 kV ¹	± 0.5 kV / ± 1 kV	Line-line 2 Ω / Line-case 12 Ω
EN 50121-3-2, IEC 62236-3-2	± 1 kV / ± 2 kV	± 1 kV / ± 2 kV	Line-line 42 Ω / Line-case 42 Ω
EN IEC 61000-4-6	10 V _{RMS}	10 V _{RMS}	AM-Modulated
EN IEC 61000-4-8	Not sensitive		Enclosure test
EN IEC 61000-4-10	Not sensitive		Enclosure test

1. Higher level 2 kV / 4 kV with external filters, contact factory.

We use the EMC product standard "Low voltage power supplies DC output" EN 61204-3 as base for measurement principles. The Immunity EMC levels are elevated in order to comply to EN 50121-3-2 (IEC 62236-3-2) Railway application: Rolling stock – Apparatus, and EN 50121-4 (IEC 62236-4) Railway application: Signaling and telecommunication apparatus. Also to meet relevant parts of IEC 61000-6-5 Generic Standards – Immunity for power stations and substation environments.



- A secure part of your system



HEAD OFFICE

Polyamp AB
Box 925
SE-191 29 Sollentuna
Sweden
Phone: +46 8 594 693 00
Telefax: +46 8 594 693 05

SALES OFFICE

Polyamp AB
Box 229
SE-597 25 Åtvidaberg
Sweden
Phone: +46 120 854 10
Telefax: +46 120 854 05

SALES OFFICE

Switch Craft S.A
Ruel bel Air 63
CH-2300 La Chaux-de-fonds
Switzerland
Phone: +41 32 96 78800
Telefax: +41 32 96 78809

Email: info@polyamp.se
www.polyamp.com